



CARRINHO Ref^a 107



*Cubo da roda em chapa



*Cubo da roda em aço vazado



Grande qualidade - Grande robustez

- ✓ Design robusto, reforçado nas zonas de maiores solicitações estáticas e dinâmicas
- ✓ Pegas em borracha para movimentação do carrinho
- ✓ Formas arredondadas e lisas, sem recantos, facilitando a descarga e a limpeza
- ✓ Deslocação silenciosa, rápida e segura, mesmo em solos irregulares
- ✓ 100% reciclável

Características gerais - Construção

- ✓ Resistência à corrosão: Total
- ✓ Material: Chassi em tubo ao carbono de 25x1,5mm e recipientes de 94Lts ou 110Lts em polietileno com cor preto ou verde
- ✓ Tampas acopladas aos recipientes
- ✓ Qualidade da chapa e tubo: Equivalente a St-37.2
- ✓ Acabamento: Chassi galvanizado a quente por imersão
- ✓ Rodas: Dois pneumáticos com Ø560mm, cubo em aço vazado

Sugestão



Opcionais / Acessórios



Características gerais - Dimensões e pesos

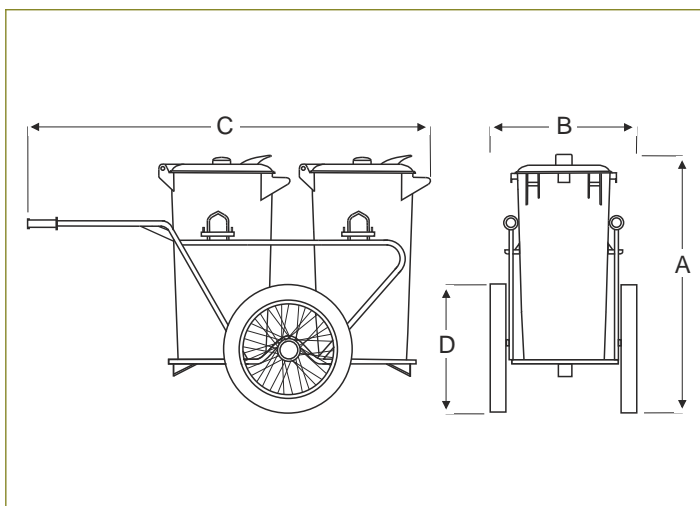

Referência	107	107/B	107/A	107/C
Cubo da roda	Aço vazado		Chapa	
Capacidade dos contentores [L]	94	110	94	110
Peso [kg]	36	37	36	37
Altura total [mm]	A	920	1055	920
Largura [mm]	B	780	780	780
Comprimento [mm]	C	1610	1610	1610
Diâmetro roda [mm] (pneumático - 2,5 / 2,75 x 17)	D	560	560	560

Cores standard



Sopinal – Fábrica de Equipamentos Urbanos e Metalurgia, Lda.

Sede / Fábrica
Rua do Vale da Relva - Vila Chã - Apartado 33 | 3731-901 Vale de Cambra - Portugal
Telef.: (+351) 256 410 770 | Fax: (+351) 256 410 779 | E-mail: sopinal@sopinal.pt

Delegação Sul
Rua Irene Isidro, nº 10 | Moinhos da Funcheira - Apartado 6064 | 2701-801 Amadora - Portugal
Telef.: (+351) 214 922 117 | Fax: (+351) 214 910 292 | E-mail: del.sul@sopinal.pt



www.sopinal.com